

5-11 Garfield Street
 Richmond Vic 3121
 Phone: 03 9416 4667
 Email: sales@ageequipment.com.au
 Website: www.ageequipment.com.au

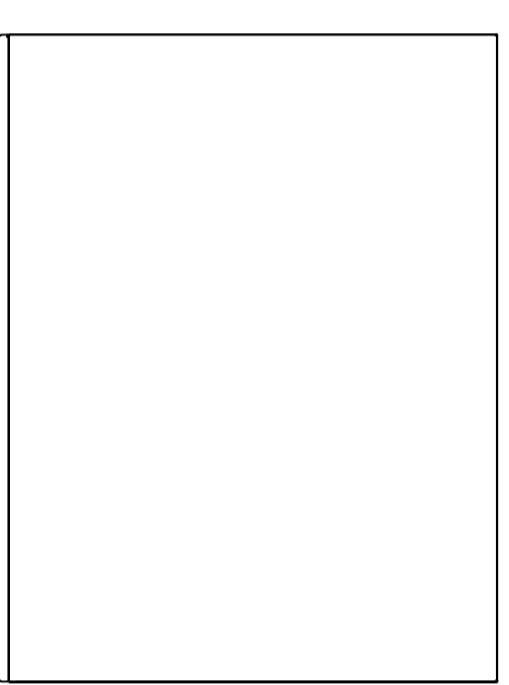
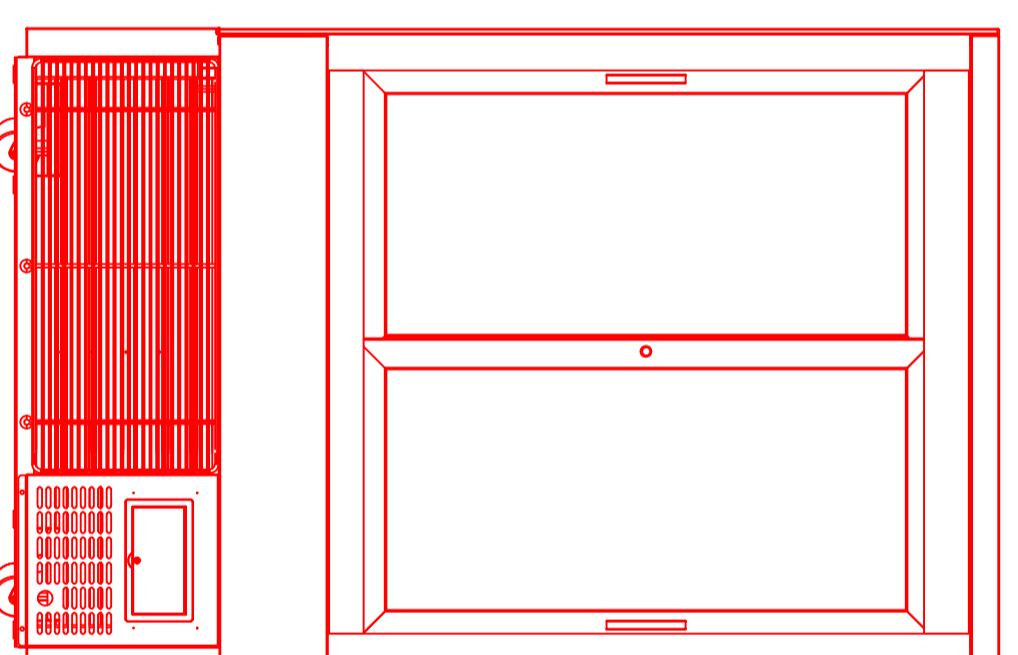
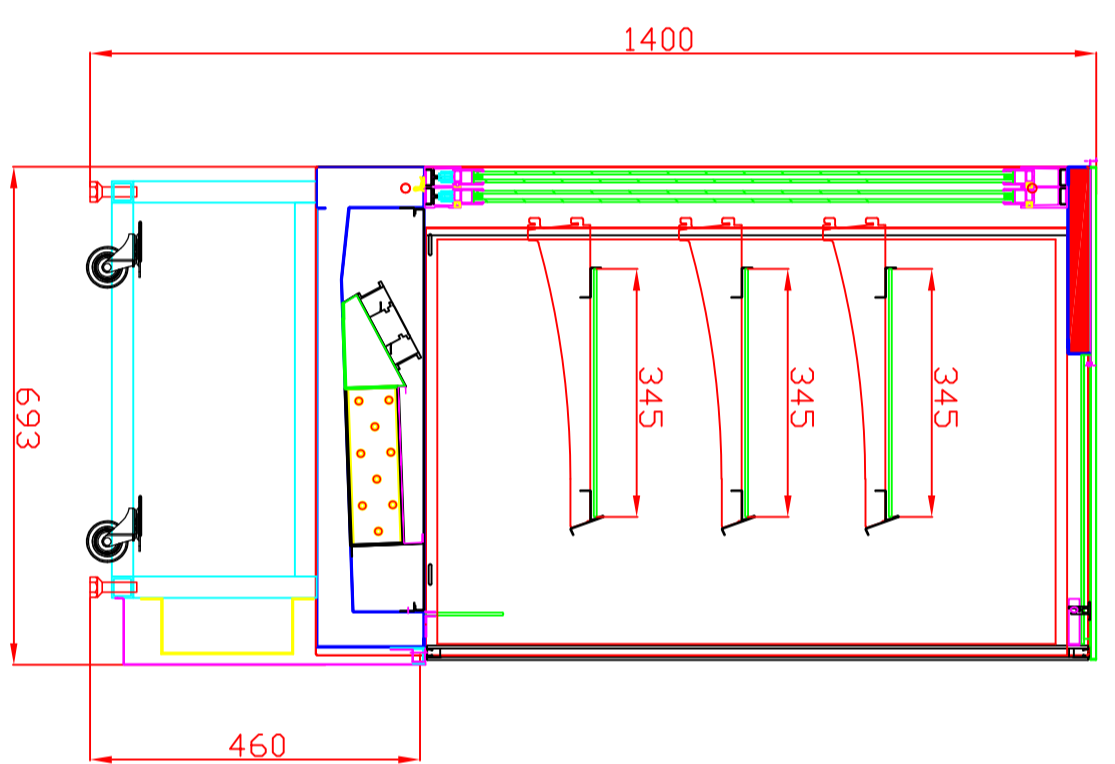
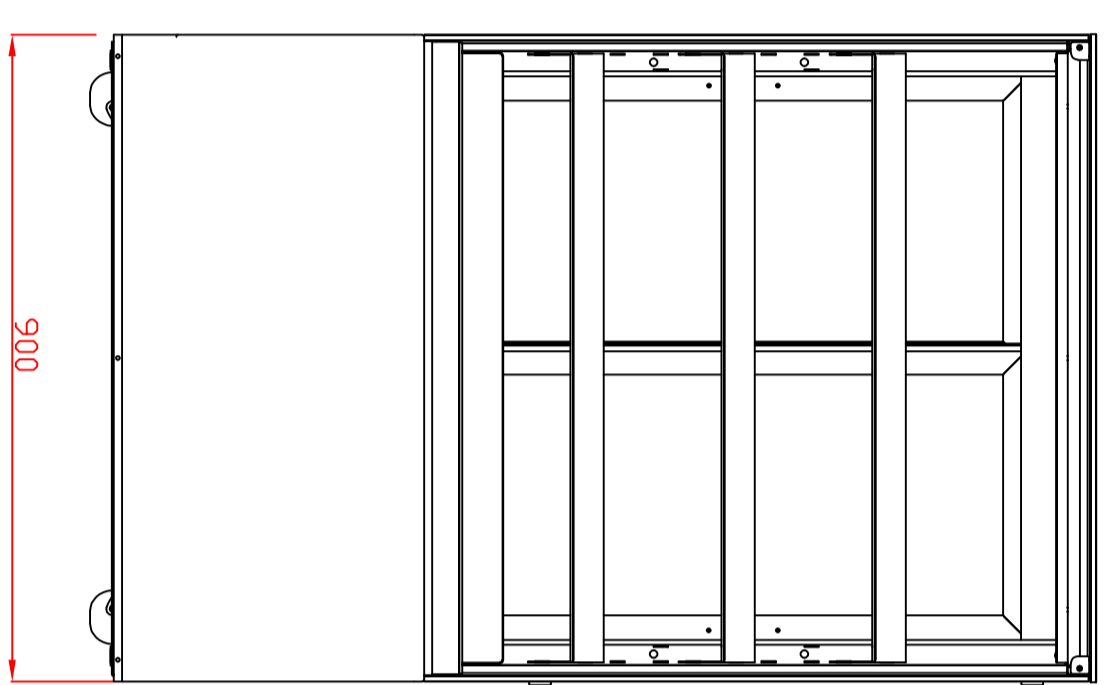
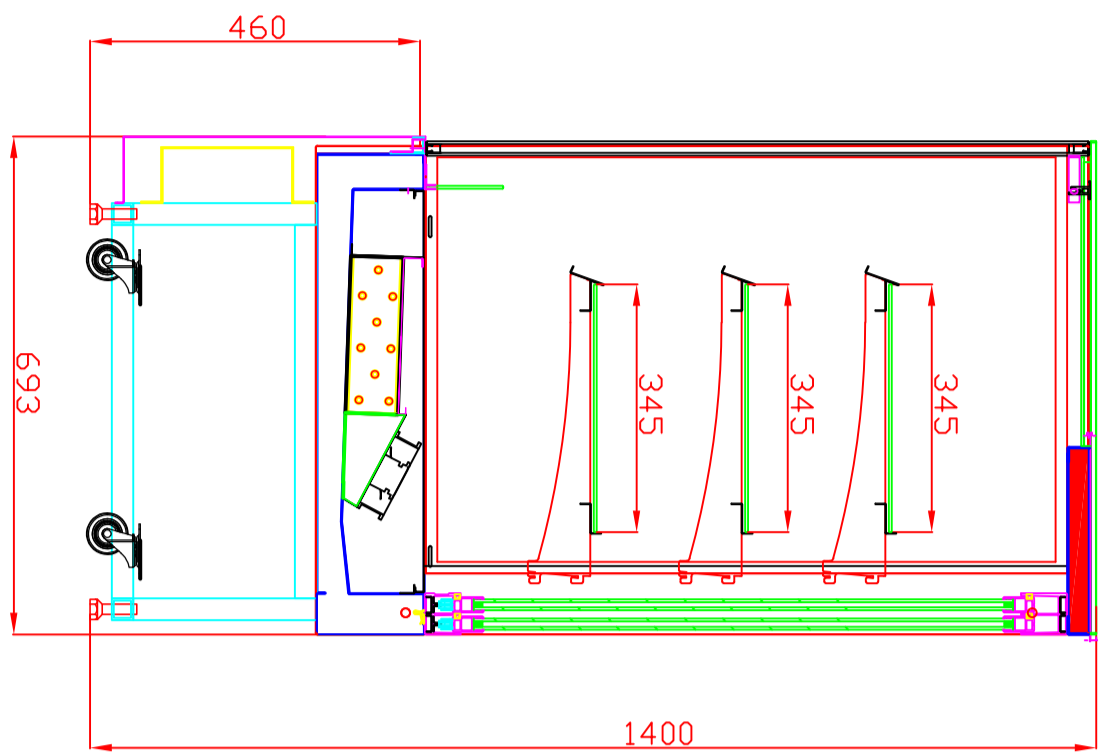

CABINET DIMENSIONS:	
Width (mm)	900
Depth (mm)	680
Height (mm)	1400
Floor Area(m ²)	0.612
EXTERNAL INTERNAL	
Width (mm)	850
Depth (mm)	560
Height (mm)	895
Floor Area(m ²)	0.612

ELECTRICAL REQUIREMENTS	
Electrical Power (W)	420
Electrical Voltage (V)	220-240
Electrical Ampere (A)	3
Electrical Frequency (Hz)	50

VENTILATION REQUIREMENTS
 The distance between the back to the wall should be 20cm

DIMENSION TOLERANCES:

Allowances for cabinets are to be between -10mm to +10mm unless noted otherwise

MODEL:
 FDF900L3

DESCRIPTION:
 Bakery Showcase