

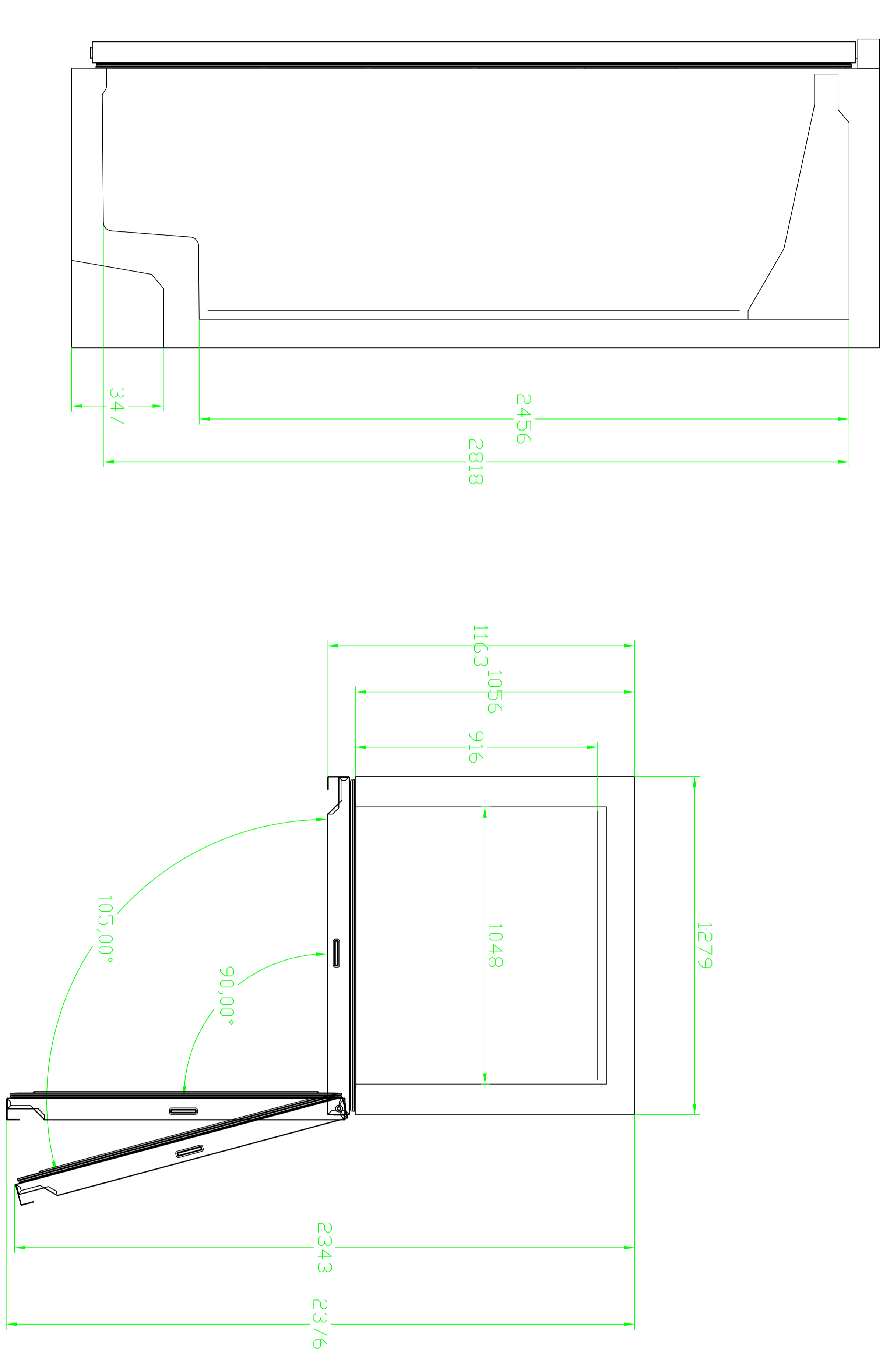

5-11 Garfield Street  
 Richmond Vic 3121  
 Phone: 03 9416 4667  
 Email: [sales@agequipment.com.au](mailto:sales@agequipment.com.au)  
 Website: [www.agequipment.com.au](http://www.agequipment.com.au)

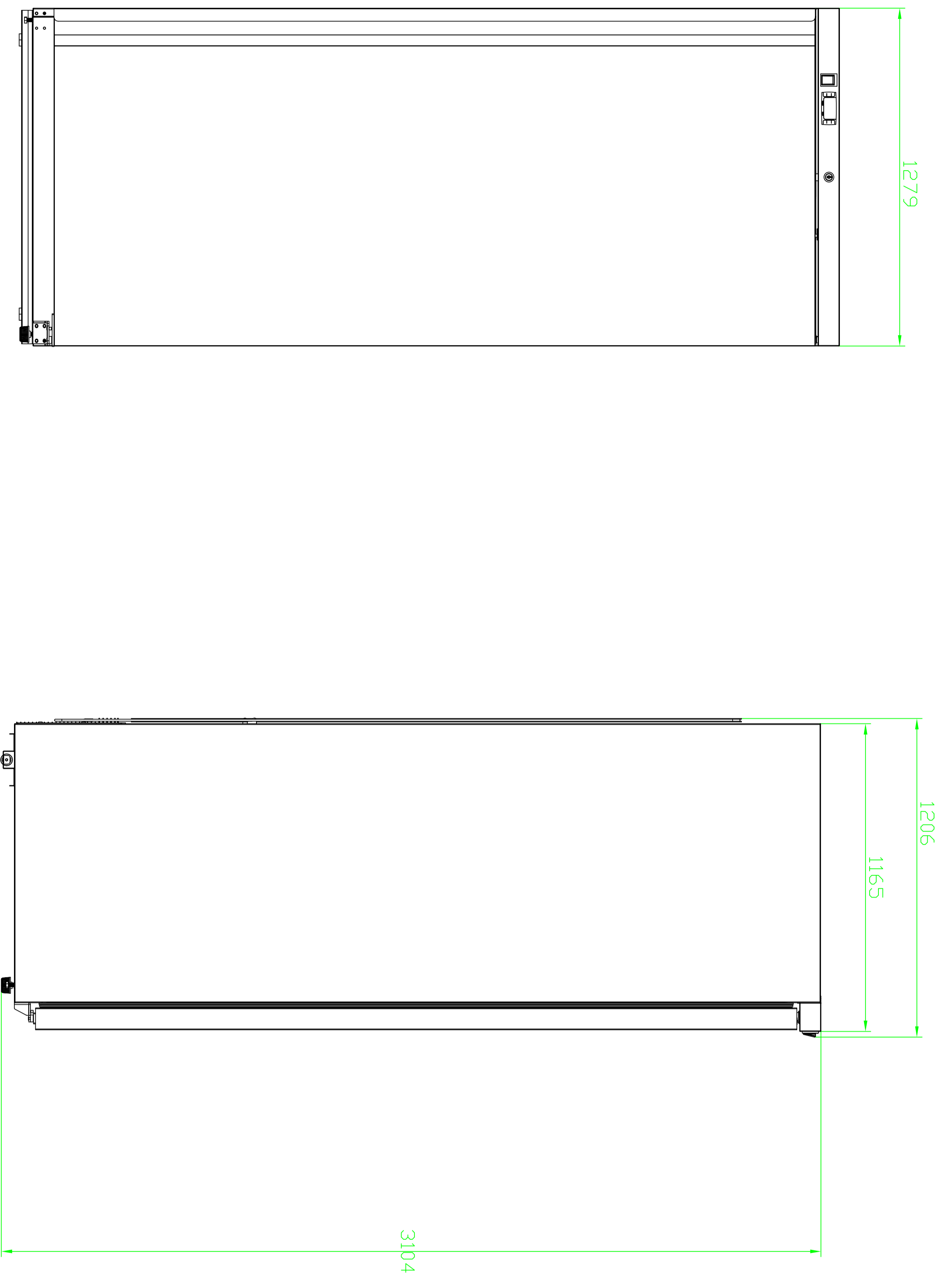

<b>CABINET DIMENSIONS:</b>	
<b>EXTERNAL</b>	<b>INTERNAL</b>
Width (mm)	775
Depth (mm)	762
Height (mm)	1882
Floor Area(m <sup>2</sup> )	1.11
<b>ELECTRICAL REQUIREMENTS</b>	
Electrical Power (W)	168
Electrical Voltage (V)	220-240
Electrical Ampere (A)	2
Electrical Frequency (Hz)	50
<b>VENTILATION REQUIREMENTS</b>	
The distance between the back to the wall should be 20cm	
<b>DIMENSION TOLERANCES:</b>	
Allowances for cabinets are to be between -10mm to +10mm unless noted otherwise	
<b>MODEL:</b>	
F600V	
<b>DESCRIPTION:</b>	
Upright Freezer	